



SpaceExplorer NT 150/750 EQ

Reflector telescope

Art. No. 9621803



Instruction manual

WARNING!



Never use a telescope for an unprotected view of the sun! When looking directly at the sun or even at its surroundings, you risk immediate and irreparable damage to your eye. Damage to the eye happens mostly painlessly and therefore without any warning to the observer, so that it is perhaps already too late as soon as an eye damage has occurred. Therefore, never point the telescope or its viewfinder at or near the sun. Never look through the telescope or its viewfinder when it is moving. During observation, children must always remain under adult supervision.

DOWNLOADS:

- Astronomy software
 - Moon map
 - Instruction Manual
- Additional literature „Astro Basics“



<http://www.bresser.de/download/9621803>

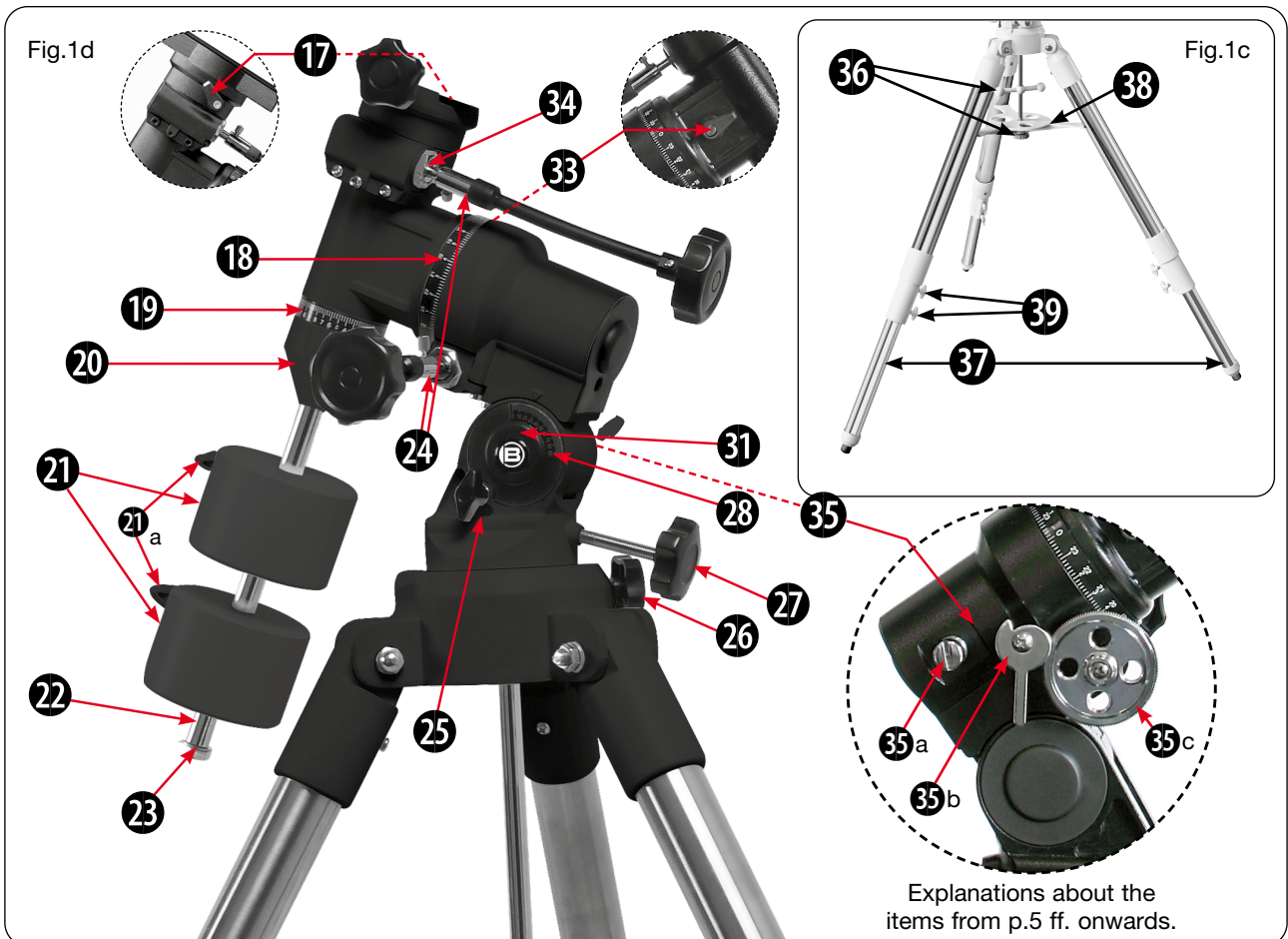
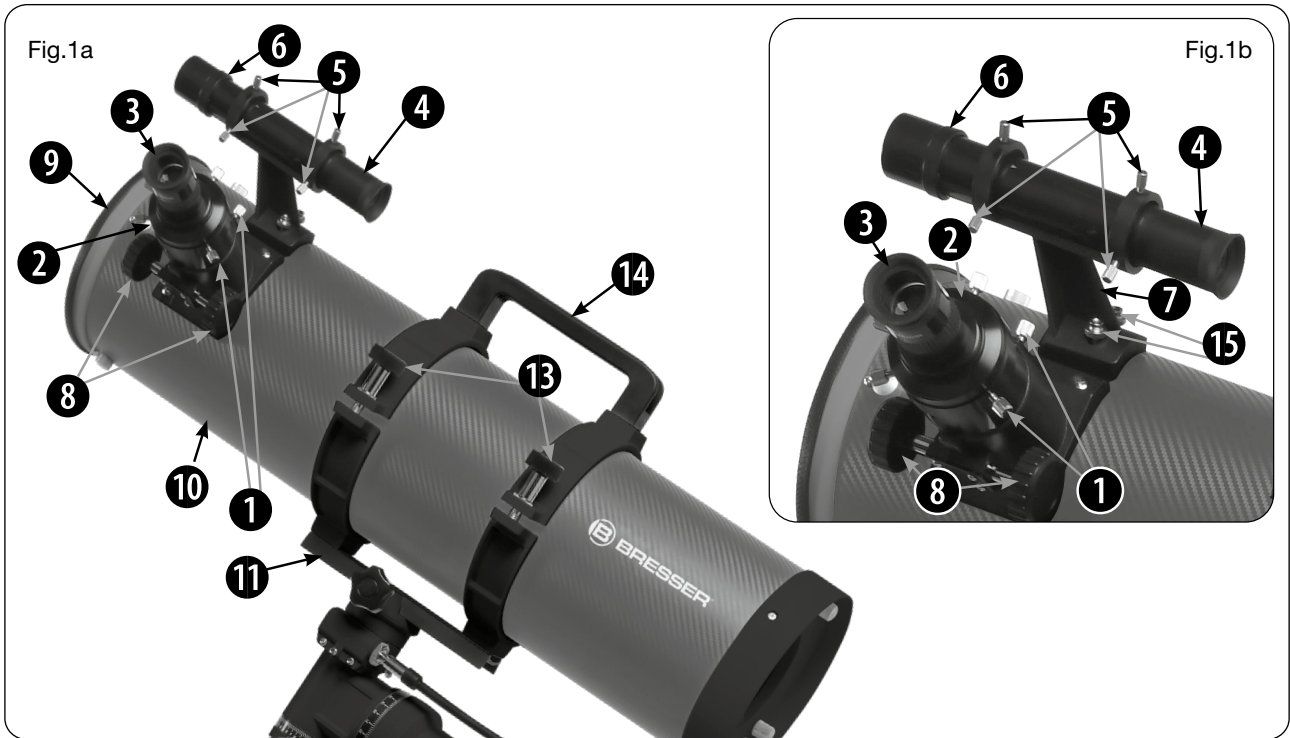

Chapter	Page
About this Instruction Manual.....	4
General warnings.....	4
Introductory words about this telescope and its use.....	5
Description of the components (according to Fig. 1a-1d)	5
Assembly	8
Listing of parts - Unpacking.....	8
Assembly instruction	8
Getting started	10
Balancing the telescope	10
ALIGNING THE VIEWFINDER.....	10
Using accessories	12
Eyepieces.....	12
Smartphone adaptor.....	12
Observation	13
Observation during manual operation.....	13
Moon Observations	13
Tracking of an object	13
The parallactic home position	14
Maintenance & Service	15
General maintenance instructions	15
Adjustment of the Newton system.....	16
Checking the optics.....	18
Technical data	18
Warranty & Service	19

About this Instruction Manual

- Read the operating instructions and the general warnings carefully before assembly and before initial commissioning.
- All BRESSER telescopes and accessories are under constant technical development. For this reason, we reserve the right to make minor changes to the product specifications in order to improve the product. This also means that illustrations may not correspond in whole or in part to the parts included in the scope of delivery. However, the general operation is the same and the assembly as well as the use of the purchased product can still be carried out as described.
- No part of this manual may be reproduced, transmitted, transcribed or translated into any language in any form without the written permission of Bresser GmbH. Errors and omissions reserved.
- Please keep this manual handy for future reference.

General warnings

DANGER OF BLINDNESS!

Never look directly at, or near to the sun with this device. There is a RISK OF BLINDNESS!

DANGER OF SUFFOCATION!

Children must only use the device under adult supervision. Keep packaging materials (plastic bags, rubber bands, etc.) away from children! There is a DANGER OF CHOKING!

FIRE HAZARD!

Do not expose this device - especially the lenses - to direct sunlight! Focusing of sunlight could cause fires.

RISK of MATERIAL DAMAGE!

Do not disassemble the device! In the event of a defect, please contact the after sales support number listed below.

Do not expose the device to high temperatures.

Protect privacy!

The binoculars are intended only for private use. Respect the privacy of your fellow human beings - do not look into the immediate living space of others (e.g. garden, apartment, etc.) with this device!

Introductory words about this telescope and its use

This telescope from BRESSER is a versatile and high-resolution optical instrument. It shows nature in even greater, detailed detail. First and foremost, it is designed to study the starry night sky. For example, it can be used to view Saturn with its distinctive rings at a distance of 1.3 billion kilometres. But also other planets or the moon, nebulae, star clusters and even far away galaxies beyond the borders of our solar system can be seen with this so called Newtonian telescope.

The handling of the mirror optics as well as the equatorial mount require a little training time in advance, in order to exhaust all the possibilities of the telescope. It is therefore recommend to study the operating instructions and the additional literature carefully. It's worth it! With the included accessories, however, simple observations can already be made once the first steps have been correctly set up and carried out.

Description of the components (according to Fig. 1a-1d)

1 For information on selecting the correct eyepiece, see the chapter "Using accessories".

For information on aligning the viewfinder, see the chapter "Aligning the Viewfinder" section.

7 For information on mounting the viewfinder, see the chapter "Assembly" (points 9 and 9a).

10 Information on the assembly of the tube and the associated components in the chapter "Assembly" (from point 7)

- 1 Eyepiece clamp screw : fixes the eyepiece in place (see point 3). Only a sensitive tightening is required.
- 2 Eyepiece holder: the eyepiece is inserted here.
- 3 Eyepiece: place the supplied eyepiece in the holder provided and fix it in place with the knurled screw (1). The eyepiece magnifies the image captured by the telescope.
- 4 Viewfinder 6x30: a telescope with low magnification and wide field of view with crosshairs that helps to align objects to the center of the telescope's eyepiece.
- 5 viewfinder adjustment screws: use these screws to align the finder scope with the telescope.
- 6 Viewfinder tube lens and counter ring: Use the lens mount to focus the viewfinder (see chap. "Aligning the viewfinder", point 3). The viewfinder is equipped with a small dust cover located at the front end.
- 7 viewfinder holders: fixes the viewfinder in place.
- 8 Focus wheel: causes a fine movement of the focussing drive to ensure a precisely focused image. The telescope can be focused in a range from about 150m to infinity. Turn the focus wheel slowly to focus on objects.
- 9 Dust cover (w/o fig.): prevents dust from entering the tube and settling on the mirrors inside, which can affect image quality.

NOTE:

The dust cover should be replaced after each observation. However, first make sure that all the dew that has accumulated during observation has completely evaporated before replacing the dust cover.

- 10 Optical tube: The most important optical component. The tube contains the main optics and thus collects the light from distant objects and brings it together in a focal point so that it can be observed through the eyepiece.
- 11 Prism rail: is being attached to the mount (see chap. "Assembly", pt. 7).
- 13 Tube clamping screws (2 pieces) with washers.
- 14 Pipe clamps with carrying handle
- Screw on tightly. Tighten the nuts firmly to secure the viewfinder holder for in place (see 4). Read more on page 10.
- 16 N/A
- 17 Declination/DEC clamping: influences the manual movement of the telescope. Turn the DEC clamp counterclockwise to release the telescope clamp. You can then rotate the telescope freely around the declination axis. By turning the DEC clamp clockwise (hand-tighten only), you prevent the telescope from being moved manually.
- 18 Right ascension axis (RA) pitch circle: More information in the accompanying booklet (download via link on p. 2).
- 19 Declination axis pitch circle (DEC): More information in the accompa-

17 ATTENTION!

Hold the optical tube when loosening the DEC clamp! The weight of the tube could cause it to suddenly swing! You could injure yourself or damage the tube.

27 For more information on setting the latitude scale, refer to the chapter "Assembly instructions", point 6.

DEFINITION:

In this manual, the terms "Right Ascension" (RA), "Declination" (DEC), "Elevation" and "Azimuth" (AZ) are mentioned several times. These terms are explained in more detail in the accompanying booklet (download via link on p. 2).

- nying booklet (download via link on p. 2).
- 20 Counterweight rod receptacle: The counterweight rod is screwed into this and then the counterweights are pushed on and clamped. Find more information in the chapter "Assembly"
- 21 Counterweight with counterweight clamping screw (21a): Balances the weight of the optical tube. Tighten the counterweight clamping screw to prevent it from slipping off the counterweight rod.
- 22 Counterweight Bar Unit: Slide the counterweight onto the counterweight rod (see 21).
- 23 Counterweight locking screw: Prevents the counterweight from accidentally slipping off the counterweight rod.
- 24 Flexible rotary shafts for the RA axis and DEC axis.
- 25 Clamping screw for the pole height. By loosening this screw, the pole height of the telescope can be adjusted with the long spindle screw 27.
- 26 Azimuth fine adjustment screws: With these screws you can adjust the horizontal rotation of the mount while centering the Polar star in the eyepiece or use the adjusted finder for this purpose first.
- 27 Pole height adjustment screws: Used to set the latitude of the observation position. By loosening the pole height clamping screw (25), the pole height of the telescope can now be adjusted.
- 28 Polar altitude scale: This allows you to read the latitude of your observing site, which you make by operating the polar altitude adjustment screw. (see chap. "Assembly", pt. 6).
- 29 N/A
- 30 N/A
- 31 Pole height axis for setting the pole height of the so-called right ascension axis: More information in the accompanying booklet (download via link on p. 2)
- 32 N/A
- 33 RA Clamp: Controls the manual movement of the telescope. By turning the RA locking screw counterclockwise, you free the telescope and allow it to rotate freely around the RA axis. Turn the screws clockwise (hand tight), close the clamp again and prevent the telescope from moving manually. However, you can now use the rotary shaft (24 below) for the fine drive of the RA axis.
- 34 DEC drive shaft
- 35 Preparation for optional tracking motor with Bracket (35a), coupling (35b) and transmission gear (35c)
- 36 Mounting connection screw. This connects the tripod head and the mount base. Hand-tighten the screws to ensure that the mount is secure.
- 37 Height adjustable tripod rod: Carry the telescope mount. The mount is placed on the tripod head (see chap. "Assembly", pt. 4).
- 38 Spreader plate with integrated accessory holder: provides spreading of the tripod legs under slight tension against the spreader plate ends and increases the stability of the tripod. Eyepieces or other accessories can be conveniently stored when not in use, but remain within reach.
- 39 Height adjustment screws for tripod legs: Loosen the screws to extend the lower tripod leg segments. Once you have reached the appropriate tripod height for you, tighten the screws again.

ASTRO TIPS

Surf the Internet



The Internet offers one of the most exciting resources for astronomy. There is a wealth of websites on the Internet with new images, discoveries and the latest astronomical information. For example, when Comet Hale-Bopp was approaching our Sun in 1998, astronomers from all over the world displayed their latest photos on a daily basis. You can find websites on the Internet for almost any topic that is somehow related to astronomy. Try the following search terms: NASA, Hubble, HST, Astronomy, Messier, Satellites, Nebulae, Black Hole, Variable Stars, etc. If you are interested in the latest product related and technical information from Bresser, check out their website. There you will find links to other astronomical websites. You can find our website at the following address: <http://www.bresser.de>

Here are some links to third party provider sites. No liability can be assumed for the content of these pages:

- Internet forum "Astronomie.de": [astronomy.com/](http://www.astronomie.com/)
- The magazine "Astronomie - DAS MAGAZIN": www.astronomie-magazin.com
- The journal Astronomy: www.astronomy.com
- Internet forum "Astrotreff": www.astrotreff.de
- Astronomical clubs and planetariums: <https://www.sternklar.de/gad/>
- Astronomy "The Picture of the Day": antwrp.gsfc.nasa.gov/apod/
- Publication Stargazing Associations: www.sternzeit-online.de
- Interstellarum magazine: www.interstellarum.com/
- Sky & Telescope magazine: www.skyandtelescope.org
- The magazine "Stars and Space": https://www.spektrum.de/lp/suw_magazin
- "Heaven's Above: Information for satellite observation": www.heavens-above.com/
- Hubble Space Telescopes Image Releases: www.spacetelescope.org
- European Southern Observatory: www.eso.org

This list is only a small selection and does not claim to be complete. The address details were current at the time of going to press and are the responsibility of the providers. Listed names are in alphabetical order.



Fig. 3: the tripod

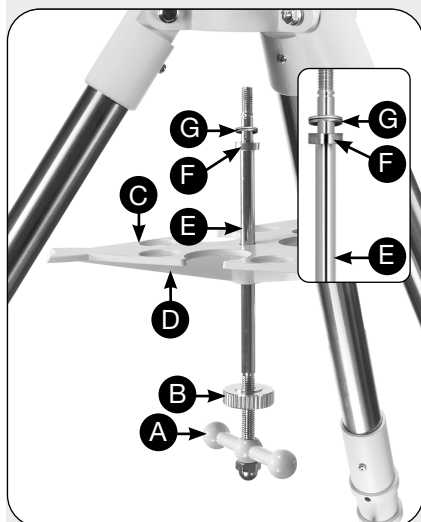

Fig. 4 Fastening of spreader plate and spacer ring

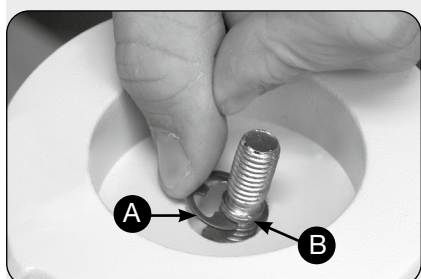

Fig. 4a: Securing the threaded rod by means of a C-clip



Fig. 5: Mounting the mount on the tripod

Assembly

Listing of parts - Unpacking

It does not take long to prepare the telescope for the first observation. When you open the package for the first time, please check the following individually packaged parts:

Telescope:

- Equatorial mount
- Height-adjustable field tripod with clamping and fixing screws
- Optical tube; dust cap, focuser, eyepiece holder, tube clamps and locking screws.
- 2 eyepieces (Plössl 10/25 mm)
- 2 Counterweights and counterweight rod
- 6x30 mm viewfinder

Instruction manual for assembling the telescope

The packages contain the tube and its individual parts, the tripod with the mount and the accessories.

1. Remove the individual parts from the packaging and also familiarise yourself with them at the same time. Use also the **images 1a to 1d** to find your way when assembling your telescope. When you take the tripod out of the packaging, keep it parallel to the ground, otherwise the inner legs of the tripod will slip out as they are not yet screwed down.
2. Locking the tripod legs. Pull the legs apart as far as possible (Fig. 3).
3. Fastening of the spreader plate. To tighten the central screw (Fig. 4, E) at the tripod, first screw the clamping nut (Fig. 4, B) all the way down, as it serves to clamp the spreader plate against the tripod legs. Now you can put the spreader plate (Fig. 4, C) from above on the central screw. Make sure that the struts (Fig. 4, D) of the spreader plate point downwards (flat surface upwards).

Attention:

It is important to perform the following step to prevent damage to the thread.

To prevent that the threaded rod (Fig. 4, E) is screwed too far into the mount, a spacer ring (Fig. 4, F) is included. put it from above on the threaded rod, so that the side with the wider cut-out is facing downwards. The spacer ring must rest on the "shoulder" of the threaded rod. Next, add the two washers (G). Now push the threaded rod through the tripod head from below and slide the C-clip from above (Fig. 4a, A) on the notch (Fig. 4a, B) of the threaded rod.

4. Attachment of the mount to the tripod head. Place the mount on the tripod head (Fig. 5). Place the mount on the tripod head so that the protruding cylinder on the bottom of the mount fits into the hole in the centre of the tripod head and secure it using the center screw. Tighten the screw hand-tight.
5. Attachment of the counterweight to the counterweight rod. Screw the base of the counterweight rod (22, Fig. 1d) to the threaded end of the declination axis (20, Fig. 1d). Then slide the counterweights (21, Fig. 1d) first onto the centre of the counterweight rod (22, Fig. 1d). If you look through the large hole in the counterweight, you will see the bolt that blocks the hole. When you move the counterweight slightly, the bolt disappears in its hole and releases the hole. If it does not, turn the counterweight clamping screw (21a, Fig. 1d) carefully until the bolt moves. Remove the counterweight lock (23, Fig. 1d) off the rod. Then, while holding the counterweight firmly, push it to about the middle of the counterweight rod (22, Fig. 1d). Tighten the counterweight locking screw securely and replace the locking screw.

NOTE:

Should the counterweight ever start to slip, the locking screw prevents it from slipping completely off the rod. Always leave the locking screw in place as long as there is a counterweight on the rod.

6. Setting the latitude: It is easier to adjust the latitude before you attach the weights and put the tube on the mount. Locate the latitude scale (28,

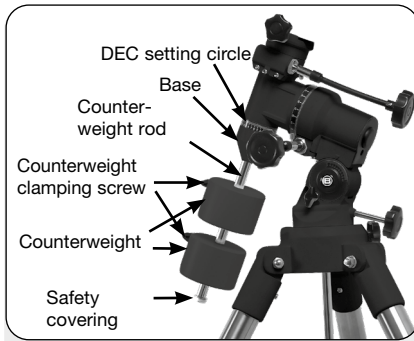

Fig. 6a: Attaching the counterweight assembly

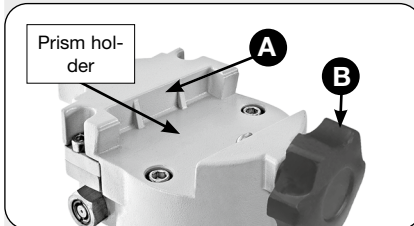

Fig. 7: Prism holder on the shaft of the mount

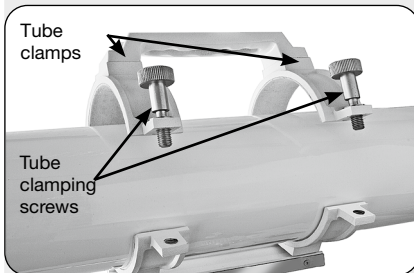

Fig. 8a: Insert the tube into the clamps and close the tube clamping screws.

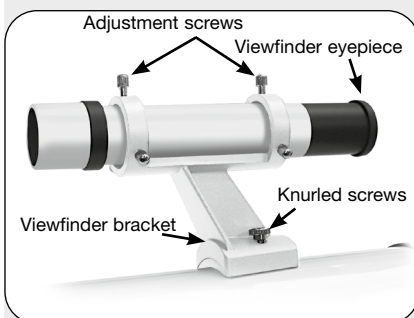

Fig. 9: Attaching the viewfinder bracket to the optical tube.

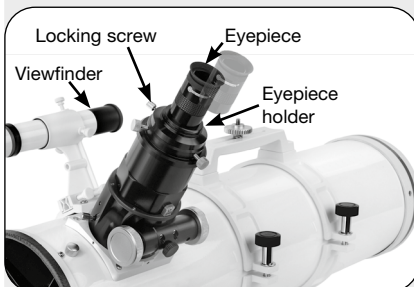

Fig. 10: Insert the eyepiece and tighten the screws.

Fig. 1d). Note that there is a triangular pointer above the scale on the mount. The pointer is not fixed. It moves as soon as the mount moves. Determine the latitude of your observation location. You can find information on this in our additional literature (download via link on p. 2) or take a look at the atlas. Loosen the clamp for the polar height (Fig. 1d, 25) and turn the polar height adjustment screw (Fig. 1d, 27) until the pointer shows the latitude you want. The adjustment screws work by an adjustment and counter mechanism (i.e. before you tighten one, loosen the other). Once the pointer shows the latitude you want, tighten both screws until they have contact with the mount.

7. Attaching the prism rail to the mount (bracket): Remove the tube from the tube clamp and slide the tube clamps connected with the prism rail (11, Fig. 1a) into the prism holder (see Fig. 7). The dovetail base of the rail fits into the prism holder of the mount (A, Fig. 7). Tighten the prism locking screw (B, Fig. 7) good on. Insert the tube into the clamps and hand-tighten the tube clamping screws.
8. Positioning of the tube in the tube clamp: Hold the tube firmly, open the tube clamping screws (13, Fig. 1a) and slightly loosen the tube clamp. While you are holding the tube (10, Fig. 1a) firmly, position it between the tube clamps so that the centre of the tube is approximately in the middle of the tube clamps. Depending on the design, align the tube so that the front side (9, Fig. 1a at the N) looks as shown on the title page. Then close the tube clamps (13, Fig. 1a) above the tube again. Tighten the screws so that they hold the tube, but you are still able to balance / to move it. For more information, see "**Balancing the Telescope**" on page 10.
9. Attaching the viewfinder (Fig. 9): The viewfinder is already included in the package with pre-mounted bracket. Remove the thumbscrews from the optical tube and set aside. Place the viewfinder bracket on the two set screws and screw the thumbscrews back on.
10. Inserting the eyepiece (Fig. 10): First remove the dust cap from the eyepiece holder on the focusing unit. Place the dust cap in a safe place and replace it when you have finished observing to prevent dirt from entering the telescope. Open the eyepiece clamping screws (1, Fig. 1a) and insert the supplied eyepiece (3, Fig.1a) into the eyepiece holder. Then hand-tighten the screws to prevent the eyepiece from slipping out.
11. Adjusting the tripod height: Adjust the tripod by loosening the locking screws (39, Fig. 1c) on the tripod. Then pull the inner tripod legs to the desired length. Then tighten the screws again. Adjust the tripod to a height that makes observing as comfortable as possible.

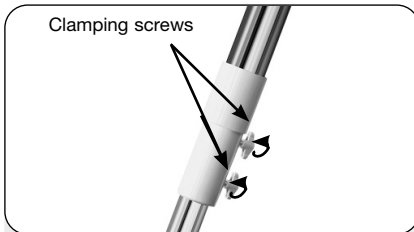

Fig. 11: Adjust the height of the tripod legs and tighten the screws.

Getting Started

Balancing the telescope

To ensure that the telescope is secure and stable on the tripod and moves smoothly and evenly, it must be balanced. To balance the telescope, open the RA clamp (33, Fig. 1d). When the axis is free, the telescope rotates around the RA axis. Later on, you will also have to open the DEC clamp (17, Fig. 1d). When is opened, the telescope will also rotate around the DEC axis. The movement of the telescope occurs around these two axes, individually or simultaneously. Try to familiarize yourself with these clamps and observe how the telescope is moving around each axis. To find the best possible balance for your telescope, follow the method described below:

1. Hold the tube tightly so that it does not swing around freely by accident. Loosen the RA clamp (33, Fig. 1d). The tube now moves freely around the RA axis. Now let the telescope rotate until the counterweight rod is parallel to the ground.
2. Open the counterweight clamping screw and slide the counterweight (21, Fig. 1d) back and forth on the counterweight rod until the telescope is in a position in which it does not move in either direction when released and is thus in balance. Then tighten the counterweight screw again so that the counterweight remains in its current position and cannot slip.
3. Then hold the tube again so that it cannot move freely. Then close the RA clamp (33, Fig. 1d) and open the DEC clamp (17, Fig. 1d) again. The telescope is now able to move freely around the DEC axis. Loosen the clamping screws of the tube clamps (13, Fig. 1a), so that the main tube can easily slide back and forth in the tube clamps. Now move the tube back and forth in the tube clamps until it stays in one position without moving in any particular direction. Then close the DEC clamp (17, Fig. 1d) and retighten the clamping screws tube clamps. The telescope is now properly balanced in both axes. The next step is to align the finder scope.

Aligning the viewfinder

The wide field of view of the viewfinder (4, Fig. 1a) is initially the better method to find objects than with the eyepiece of the telescope, which offers a much smaller field of view. If you have not yet attached the viewfinder to the main telescope, follow the instructions as described from step 9 on page 9. For the viewfinder to be useful at all, it must first be aligned parallel to the main telescope. What is displayed in the center of the viewfinder must also be visible in the centre of the eyepiece of the telescope (in this case, the viewfinder would already be adjusted !). This alignment makes it easier to find objects. First, find an object in the field of view of the viewfinder and then look through the eyepiece of the main telescope to get a more detailed view. To align the viewfinder, it is best to perform steps 1 to 4 below during the day or at dusk, and step 5 at night.

1. Remove the dust caps from your telescope and - if present - from the viewfinder.
2. If not already done, place the eyepiece (3, Fig. 1b) into the eyepiece holder of the main telescope. See step 10, page 9.
3. Now look through the viewfinder and find an object that is at least 1000m away. (TIP: Remove the viewfinder from the holder to facilitate the following action). If the distant object can only be seen indistinctly / out of focus, turn the counter ring slightly counterclockwise to loose the lens mount (6, Fig. 1b) of the finder scope a little bit. Now turn the lens mount until the desired sharpness is set and tighten the counter ring again.
4. Loosen the RA clamp (33, Fig. 1d) and the DEC clamp (17, Fig. 1d), so that the telescope moves freely in both axes. Now point the main telescope at a large, clearly visible fixed land object (e.g. a church spire, a high-voltage pylon or another prominent fixed point) located at a distance of at least 1000m and bring it to the centre of the eyepiece of the main telescope. Focus the image by turning the focusing knob (8,

Fig. 1b). Then tighten the RA and DEC clamps again.

5. Look through the viewfinder and, if necessary, loosen or tighten one or more of the viewfinder adjustment screws (5, Fig. 1b) until the crosshairs are exactly on the object that you have also selected with the eyepiece of the main telescope.

Now your viewfinder is adjusted and you can make your first observation.

ATTENTION!

NEVER point the telescope or the viewfinder at or near the sun! Observing the sun will inevitably lead to immediate and irreparable eye damage – even if it lasts only the tiniest fraction of a second. In addition, your telescope itself will also be damaged.

6. For more accurate viewfinder adjustment, perform this alignment on a celestial object such as a bright star or the moon, and make any necessary fine adjustments. Proceed as described in steps 3 and 4.

With this alignment, objects that were first seen in the wide field of view of the viewfinder will also be seen in the eyepiece of the main telescope.

ASTRO TIPS

Further studies / additional literature

This instruction manual provides only the most important information on using the telescope. In order to make full use of the manifold possibilities of the instrument, you should definitely delve deeper into the subject of "astronomy". For this purpose, we have compiled some helpful information in an accompanying booklet, which you can download free of charge via the following weblink:
<http://www.bresser.de/download/9621803>

Furthermore, we have listed below topics that are also worth taking a closer look at. Below you will find a list of books, magazines and organizations that may be of use to you.

Topics

1. How a star is "born"? How a solar system is formed?
2. How to measure the distance of a star? What exactly is a light year?
3. What is a red and blue shift?
4. How were the craters of the moon formed? How old are the earth and the moon?
How old is the Sun?
5. What is a "black hole", a "quasar", a "neutron star"?
6. What are the stars made of? Why do the stars have different colours?
What is a "white dwarf", what is a "red giant"?
7. What is a "nova", a "supernova"?
8. What can we imagine among comets, asteroids, meteors, meteor showers? Where do they come from?
9. What is a „planetary nebula“? What is a "globular cluster"?
10. What does the term "big bang" mean? Is the universe expanding or contracting together? Does the universe always remain the same?

Books

1. Skywatching by David H. Levy
2. The Cambridge Star Atlas by Wil Tirion
3. Night Sky Almanac, Night Sky Guide and other

Magazines

2. Astronomy
3. Sky & Telescope

Organizations

1. Association of Stargazers e.V. / Germany (VdS)
2. astronomy.com/community

This list is only a selection and does not claim to be complete.

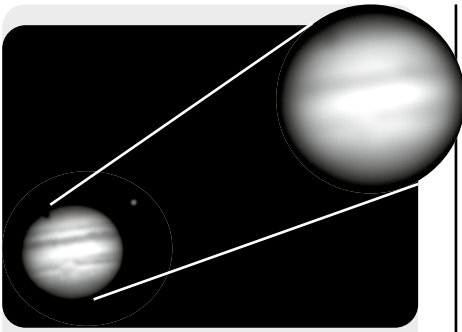

Fig. 15a: The planet Jupiter. An example of correct (left) and too much magnification (right)

Visibility conditions vary greatly from night to night and depend largely on the observation site. Air turbulence also occurs during apparently clear nights and distorts the image of objects. If an object appears blurry and poorly defined, go back to an eyepiece with a lower magnification. This will give you a sharper, better defined image (Fig. 15a).

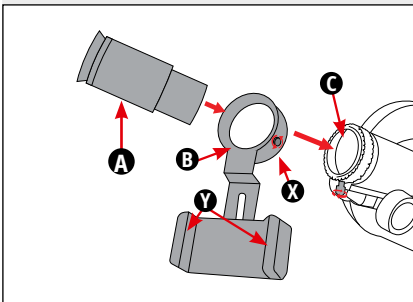

Fig. 17: Attaching the Smartphone adaptor to the eyepiece socket.

Using accessories

Eyepieces

The main function of a telescope eyepiece is to magnify the image produced by the main optics of the telescope. Each eyepiece has a specific focal length, which is specified in millimetres (mm). The smaller the focal length, the greater the magnification. Thus, an eyepiece with a focal length of 20mm produces a higher magnification than an eyepiece with 25mm.

Long focal length eyepieces provide a wide field of view, bright high contrast images and reduce eye fatigue during long periods of observation. If you are looking for an object with a telescope, you should always start with a lower magnification eyepiece (e.g. 25mm). Then, when the object is found and is in the center of your eyepiece, you can use a higher magnification eyepiece and enlarge the image as much as the prevailing weather conditions will allow.

The magnification of a telescope is determined by the focal length of the telescope itself and the focal length of the eyepiece used. To calculate the power of the eyepiece, divide the focal length of the telescope by the focal length of the eyepiece. Here is an example using a 25 mm eyepiece. (see "Technical data" from page 18).

Telescope focal length / focal length of the eyepiece = magnification of the eyepiece

Telescope focal length = 750mm

Focal length of the eyepiece = 25mm

$$\text{Magnification} = \frac{\text{Telescope's focal length}}{\text{Eyepiece's focal length}} = \frac{750\text{mm}}{25\text{mm}} = 30$$

The magnification is therefore 30x.

Smartphone adaptor

With this adaptor, a smartphone can be mounted to the telescope to capture bright, flat objects (e.g. the moon) or - depending on the sensor sensitivity of the smartphone - also planets.

For mounting, insert the eyepiece (A, Fig. 17) through the mounting ring (B, Fig. 17) of the Smartphone adaptor and fix it with the thumbscrew (X, Fig. 17). Insert the eyepiece with the attached Smartphone adaptor into the eyepiece socket (C, Fig. 17).

Place the Smartphone between the two retaining jaws (Y, Fig. 17) of the Smartphone adaptor so that the camera lens is directly and centrally above the eyepiece lens.

ASTRO TIPS

Is it even possible to choose a magnification that is "too high"?

Yes, you can! The most common mistake made by beginners is to over-magnify the image produced by the telescope. A very high magnification is selected, which the telescope cannot provide due to its construction, weather or light conditions. Therefore, always keep in mind that a sharp but low magnification image (Fig. 15a, lower left) is much nicer to look at than a highly magnified but completely blurred image (Fig. 15a, right), which you will definitely not enjoy. Magnifications above 200x should only be selected when the air is absolutely calm and clear. Most observers should have three or four extra eyepieces on hand to take advantage of the full range of magnifications possible with the telescope.



Observation

Observation with manual operation

After the telescope is assembled and balanced as described, you are ready for manual observation. Pick an easy-to-observe object on Earth such as a street sign or traffic light and familiarize yourself with the telescope's functions. To achieve the best possible result, please observe the following instructions:

- To locate an object, first loosen the RA clamp (33, Fig. 1d) and the DEC clamp (17, Fig.1d). The telescope can now move freely around its axes. First loosen the clamps individually and familiarise yourself with the individual movements. Then loosen both clamps at the same time. It is important that you familiarise yourself with all the movements of your telescope, as handling a parallactic mount can take some getting used to, especially at night in complete darkness.
- Now use the finder scope to locate the object of your choice. When you have the desired object in your sights, close the RA and DEC clamps again.
- The eyepiece of a telescope magnifies the image captured by the telescope's primary mirror. An eyepiece works like a magnifying glass. Each eyepiece has a focal length, expressed in millimeters (mm). The smaller the focal length, the higher the magnification. For example: an eyepiece with a focal length of 9mm has a higher magnification than an eyepiece with a focal length of 26mm. Eyepieces with a lower magnification offer a larger field of view, provide brighter and higher contrast images and are more comfortable for the eye during longer observations. At the beginning of an observation, you should always start with a weaker eyepiece, such as the supplied Plössl 25 mm. When the desired object is centred and focused, you can switch to a larger eyepiece to magnify the object as high as the observing conditions will allow.
- Once centered, an object can be focused by using the focusing wheels on the focusing unit (8 Fig. 1b). However, keep in mind that the desired object will slowly move out of field of view due to the rotation of the earth on its own axis. This impression is even reinforced at high magnification.

Moon Observations

Point the telescope (picture: (Keep in mind, however, that the moon is not visible every night) Now practice using the different eyepieces to observe different details on the moon. There are many different details to look at on the moon, such as craters, mountain ranges, and grooves. The best time to observe the moon is during its crescent or sickle phase. At this time, the sunlight hits the moon at a very shallow angle, giving its appearance a vivid depth. At full moon there are no shadows to be seen at all, which makes the surface of the moon look very bright, flat and uninteresting. Therefore, when viewing the moon, you may want to consider using a neutral density moon filter. Among other things, this not only dampens the glaring light of the moon, but also increases the contrast at the same time.

Tracking of an object

As the earth rotates under the night sky, the stars appear to move from east through south (where you reach the highest distance above the horizon) to west. The speed with which the stars perform this movement is called "sidereal velocity".

IMPORTANT NOTE:

Objects viewed through the viewfinder appear upside down and upside down.

Objects observed through the eyepiece of the main tube, which sits on the telescope via a zenith prism, appear upright but also laterally inverted.

This effect does not interfere with the observation of astronomical objects. Incidentally, these effects occur with all astronomical telescopes.



WARNING!

Never use a tele-scope for an unprotected view of the sun! As soon as you look directly at the sun, or even at its immediate surroundings, you risk immediate and irreparable damage to your eye. This damage to the eye usually occurs painlessly and therefore without any warning to the observer that perhaps everything is already too late and that eye damage has occurred. Therefore, never point the telescope or its viewfinder at or near the sun. Never look through the telescope or its viewfinder when it is moving. During an observation, children must remain under adult supervision at all times.

IMPORTANT NOTE:

Increase your observing comfort by retrofitting the optionally available tracking motor. This can be attached to the holder (9a) of the mount (9). The electrical tracking keeps the observation object in the field of view of the eyepiece even over longer periods of time; manual tracking is no longer necessary. Contact the service department for more information.

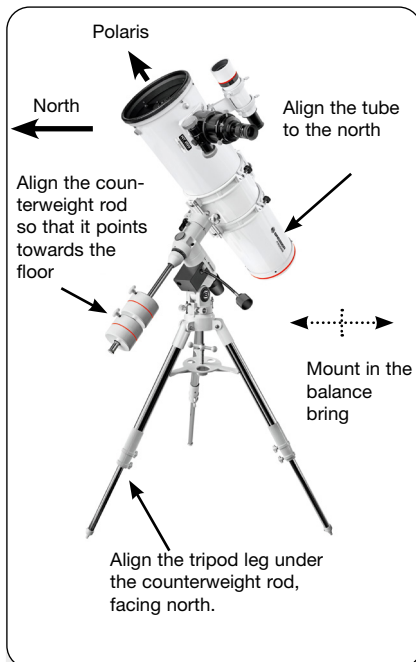

Fig. 16a: The parallactic home position, side view



Fig. 16b: The parallactic home position seen from the north. The RA axis and the parallel tube point to the polar star (Polaris).

The parallactic home position

1. Balance the mount; if necessary, adjust the height of the tripod legs.
2. Loosen the RA clamp (33, Figure 1d). Swivel the tube until the counterweight rod points directly to the ground (see also Fig. 16a and 16b).
3. If you have not already done so, align the entire telescope assembly, so that the tripod leg under the counterweight rod faces (approximately) to the north. Then open the DEC clamp (33, Fig. 1d), so that the optical tube (10, Fig. 1a) can be swivelled. Now turn the tube until it points to the north and ideally to the North Star (Polaris). Then close the clamps again. More information on finding the North Star in the accompanying booklet (download via link on p. 2).
4. If you have not already done so, determine the latitude of your observation location. Use the adjustment screws for the latitude (27, Fig. 1d) to adjust the telescope mount, so that the pointer points exactly to the correct latitude of your observing site on the latitude scale (28, Fig. 1d). More information on latitude determination in the additional literature (download via link on page 2).
5. If steps 1 through 4 have been performed reasonably accurately, your telescope is now sufficiently well aligned with Polaris, the North Star, and you can begin making observations.

Once the mount has been aligned with the polar star as described above, it is not necessary to adjust the latitude setting again, unless you move your observation to a completely different geographical location (different latitude setting required).

IMPORTANT NOTE:

For almost all astronomical observing requirements, approximate estimates of latitude are quite acceptable. So don't let excessive attention to the exact position of the polar star take away the joy of your telescope.

General instructions for maintenance

This telescope is considered a precision optical instrument that will give you many years of enjoyment. As long as you give your telescope the care and attention due a precision instrument, you will very rarely need factory service or other appropriate maintenance.

IMPORTANT NOTE:

Always strictly adhere to the instructions given here in case of possible maintenance. Since this is a sensitive opto-mechanical instrument, even the smallest steps performed incorrectly can cause irreparable damage to the device! The manufacturer accepts no liability for damage resulting from improper handling or maintenance!

The following points should be noted:

- A Avoid cleaning the telescope optics too frequently. A little dust on the front of your telescope's lens, or on the mirror surface, causes virtually no reduction in imaging quality, and so a little dust should not cause you to constantly clean the optical surfaces.
- b. Only if absolutely necessary, the jam on optical surfaces can be removed with gentle movements of a fine photo brush. You can also blow the dust away with a small bellows. However, do not use any photographic lens cleaners under any circumstances!
- c. Organic soiling (fingerprints, etc.) on optical surfaces is best removed with a cleaning fluid consisting of three parts distilled water and one part isopropyl alcohol. You may add a small drop of biodegradable dish-washing liquid per half litre of cleaning liquid. Also, use only soft, white cosmetic wipes, make short, careful wiping motions, and change wipes as often as possible.

Attention:

Do not use fragrance impregnated, dyed or lotion soaked cloths as they will damage your optics.

- D Never, for any reason, remove the optics from their mount; not even to clean them or for any other reason. You would probably not be able to reinsert them at the exact position and risk a serious degradation of the optical performance of your telescope. In such cases, Bresser accepts no liability whatsoever for any damage incurred.
- e If your telescope is used outside during a humid night, dew may settle on the surface of the telescope. Normally, such wetness does not cause any damage, but it is strongly recommended to dry the telescope with a suitable cloth each time before storing it. However, never wipe the optical surfaces dry! Instead, leave the telescope in a warm room for a while so that the damp optical surfaces can dry by themselves. Wait until the telescope is completely dry before repacking it.
- f. Never leave your telescope in a locked car on hot summer days. Excessive temperatures can affect the internal lubrication.

IMPORTANT NOTE:

You should only carry out the maintenance procedure described below by yourself if you are already familiar with this technical procedure, as even smallest errors during the adjustment can cause damage to the device! The manufacturer accepts no liability for damage resulting from improper handling or maintenance!

We recommend that untrained users and users with little previous knowledge consult our service department before carrying out an adjustment (for more information, see the chapter "Warranty and Service"). Any maintenance/service that may be required is subject to a charge.

Adjustment of the Newton system

All Newtonian telescopes are precisely collimated at the factory before shipment. However, it may happen that the optical system is misaligned due to vibrations during transport and has to be re-collimated. However, readjusting the optics is quite simple.

However, performing collimation on an NT 150/750 telescope is a little different from other Newtonian reflector telescopes due to the fast focal ratio of f/5 of the primary mirror. Let's look at the image of a typical Newtonian reflector telescope. When the observer looks through the telescope (without eyepiece), the eye of the observer, the secondary mirror, primary mirror and eyepiece extension appear relatively exactly centered in the middle. (see figure 7). On the other hand, with a "fast" focal ratio (f/5 or f/4 or smaller) of a Newtonian telescope, the secondary mirror must be offset in two directions from the centre: 1. away from the focuser and 2. towards the main mirror (by the same amount). This so-called "offset" is a few mm in both directions. Remember that these settings were made at the factory before the telescope was shipped. We mention it here only so you can check that the optics have not been badly misaligned. For fine adjustment, please follow step 4 of the description below.

- ② Eyepiece extension (profile)
- ② Secondary mirror
- ③ Reflection of the primary mirror
- ④ Reflection of the secondary mirror
- ⑤ Reflection of the observer's eye
- ⑥ Retaining clips of the primary mirror

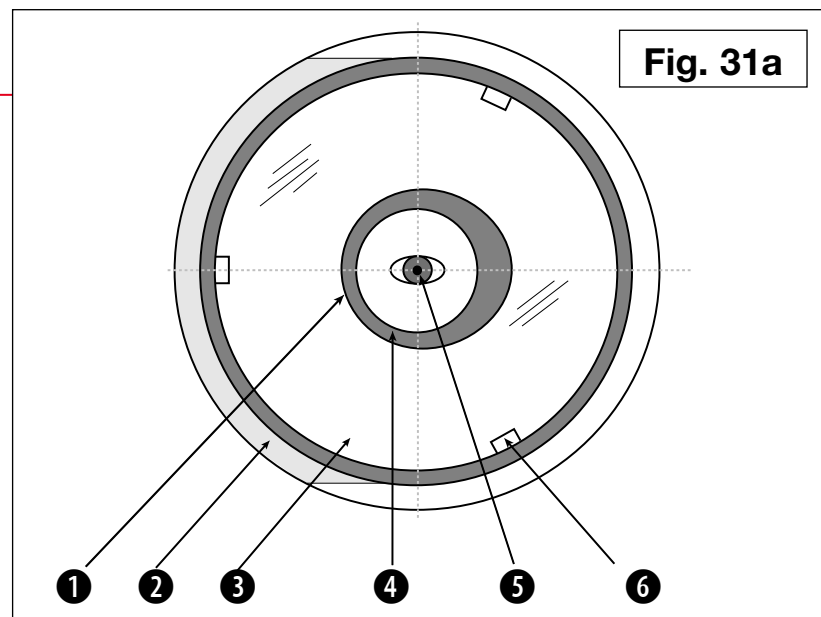

Fig. 31a is showing the view through a correctly collimated Newtonian telescope as seen through a focuser without eyepiece.

For checking and possibly new optical collimation, please proceed as follows:

1. Look through the focuser and rotate the tube in the tube clamps so that the telescope's primary mirror is on your right and the telescope's secondary mirror is on your left. The secondary mirror, as already shown (2, Fig. 31a), appears in the middle. If the secondary mirror is not in the middle, it must be centred by using the 3 adjustment screws and the central retaining screw for the secondary mirror height adjustment which is located in the plastic housing of the secondary mirror.
2. If the reflection of the primary mirror (3, Fig.31a) is not centered on the surface of the secondary mirror, first center it with the 3 adjustment

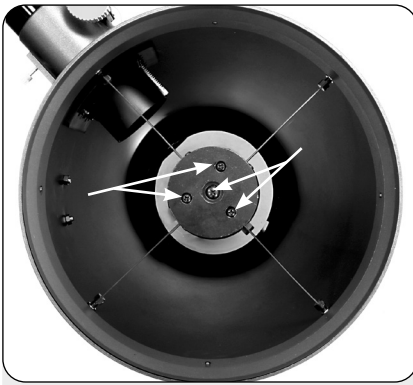

Fig. 31b: The four collimation screws in the secondary mirror housing

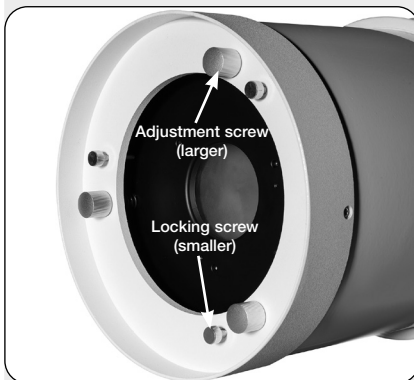

Fig. 31c: The six collimation screws on the underside of the primary mirror cell

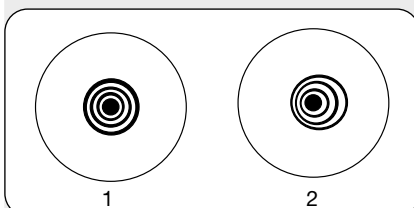

Fig. 32: correct (1) and incorrect (2) collimation.

screws and, if necessary, by loosening the central screw located in the plastic housing of the mirror.

As described above, the 4 collimation screws (Fig. 31b) in the plastic housing of the secondary mirror are used for two different adjustments procedures being possible during the collimation.

IMPORTANT NOTE:

Never tighten the 4 collimation screws (Fig. 31b) with heavy force above their normal stop. Never unscrew the collimation screws more than two full turns counterclockwise (no more than two full turns in the loosening position). Otherwise the secondary mirror could loosen in its holder. You will probably find out very quickly that these adjustments have to be made very carefully. Normally, half a turn is sufficient to achieve the desired result.

3. If the reflection of the secondary mirror is not exactly in the center of the primary mirror, adjust the primary mirror with the 3 collimation screws located at the bottom of the primary mirror.

NOTE:

There are six screws on the primary mirror cell (Fig. 31c). The three corrugated knobs are collimation screws and the 3 slightly smaller screws are the so-called counter screws. These will hold the primary mirror in position. These will hold the primary mirror in position. These counter screws must be slightly loosened so that you can turn the collimation screws. It will probably take you some time to get a feel for which of the collimation screws will change the image as desired.

4. Now perform the test on a star to verify the correctness of steps 1 to 3. Using a standard eyepiece (20-26mm), point the telescope at a reasonably bright star (2nd or 3rd grade magnification) and position this star centrally in the field of view of the main telescope.
5. Slowly "move" the image out of focus until you see several circles around the center of the star. If steps 1 to 3 are performed correctly, you will see concentric circles (centered to each other) (1, Fig. 32).

If the device is not carefully collimated, you will discover eccentric circles (2, Fig. 32). Adjust the three collimation screws on the primary mirror housing until the circles inside and outside the focus are concentric.

It is only important that at the end of the primary mirror collimation the counter screws are tightened one after the other with a lot of feeling for several times. Because they now hold the primary mirror tilt-free in the optimally determined position in the primary mirror cell. Always check the collimation image (Fig. 32) (also called diffraction pattern).

TIP: Alternatively, instead of a bright star, you can conveniently perform the collimation with an alignment laser (optionally available).

Summarized again: The four adjustment screws on the plastic housing of the secondary mirror change its tilt angle so that it is correctly centered in the middle of the eyepiece extension tube and the primary mirror also appears centered when looking into the eyepiece extension. The three thicker collimation screws on the primary mirror change its tilt angle so that it reflects the light directly into the center of the eyepiece extension tube.

TIP: A large number of instructions for adjusting/collimating Newtonian telescopes can be found, e.g. in the Internet or in reference books.

Checking the optics

Some notes on the so-called "flashlight test":

If you shine a flashlight or an even more powerful light source into the telescope's optical tube, you might find something that looks like scratches or dark or light spots, or even uneven varnish, depending on the angle of the light and the observer's point of view. This could possibly give the impression of poor optical quality. The effect of these phenomena on the optical quality can only be proven with a very large physical measurement effort and do not limit the function and quality of the high quality optics in the night sky in any way and do not represent a justified defect for a complaint. They can only be detected when a light source that is much more

intense shines through a lens or is reflected by a mirror. These effects can also occur with any other high-quality optical system, even with gigantic telescopes used for research.

Conclusion: The optical quality of a telescope can therefore not be judged solely on the basis of the "flashlight test". Reliable control of the optical quality can only be achieved by careful testing on a star.

Warranty

The regular warranty period is 5 years and begins on the day of purchase. You can consult the full guarantee terms as well as information on extending the guarantee period and details of our services at www.bresser.de/warranty_terms.

In case of warranty or other service requests, please contact the customer service responsible for your country beforehand, preferably by e-mail.

Technical data

SpaceExplorer NT 150/750 EQ

Item number	9621803
Optical design	Newtonian reflector telescope
Aperture	6" = 150 mm
Focal length	750 mm
Focal ratio / photographic aperture	f/5
Maximum resolution	0.76 arcseconds
Mounting	equatorial/parallactic
RA and DEC drive/movement	manual, via flexible shafts
Max. useful magnification	300x
Tripod	height adjustable field tripod



Service

DE AT CH BE

Bei Fragen zum Produkt und eventuellen Reklamationen nehmen Sie bitte zunächst mit dem Service-Center Kontakt auf, vorzugsweise per E-Mail.

E-Mail: service@bresser.de
Telefon*: +49 28 72 80 74 210

BRESSER GmbH

Kundenservice
Gutenbergstr. 2
46414 Rhede
Deutschland

*Lokale Rufnummer in Deutschland (Die Höhe der Gebühren je Telefonat ist abhängig vom Tarif Ihres Telefonanbieters); Anrufe aus dem Ausland sind mit höheren Kosten verbunden.

GB IE

Please contact the service centre first for any questions regarding the product or claims, preferably by e-mail.

E-Mail: service@bresseruk.com
Telephone*: +44 1342 837 098

BRESSER UK Ltd.

Suite 3G, Eden House
Enterprise Way
Edenbridge, Kent TN8 6HF
United Kingdom

*Number charged at local rates in the UK (the amount you will be charged per phone call will depend on the tariff of your phone provider); calls from abroad will involve higher costs.

FR BE

Si vous avez des questions concernant ce produit ou en cas de réclamations, veuillez prendre contact avec notre centre de services (de préférence via e-mail).

E-Mail: sav@bresser.fr
Téléphone*: 00 800 6343 7000

BRESSER France SARL

Pôle d'Activités de Nicopolis
314 Avenue des Chênes Verts
83170 Brignoles
France

*Prix d'un appel local depuis la France ou Belgique

NL BE

Als u met betrekking tot het product vragen of eventuele klachten heeft kunt u contact opnemen met het service centrum (bij voorkeur per e-mail).

E-Mail: info@bresserbenelux.nl
Telefoon*: +31 528 23 24 76

BRESSER Benelux

Smirnoffstraat 8
7903 AX Hoogeveen
The Netherlands

*Het telefoonnummer wordt in het Nederland tegen lokaal tarief in rekening gebracht. Het bedrag dat u per gesprek in rekening gebracht zal worden, is afhankelijk van het tarief van uw telefoon provider; gesprekken vanuit het buitenland zullen hogere kosten met zich meebrengen.

ES IT PT

Si desea formular alguna pregunta sobre el producto o alguna eventual reclamación, le rogamos que se ponga en contacto con el centro de servicio técnico (de preferencia por e-mail).

E-Mail: servicio.iberia@bresser-iberia.es
Teléfono*: +34 91 67972 69

BRESSER Iberia SLU

c/Valdemorillo,1 Nave B
P.I. Ventorro del Cano
28925 Alcorcón Madrid
España

*Número local de España (el importe de cada llamada telefónica dependen de las tarifas de los distribuidores); Las llamadas des del extranjero están ligadas a costes suplementarios..

Bresser GmbH
Gutenbergstraße 2
46414 Rhede · Germany
www.bresser.de

    @BresserEurope



© 2021 Bresser GmbH, 46414 Rhede, Germany.
No part of this manual may be reproduced, transmitted, transcribed or translated into any language in any form without the written permission of Bresser GmbH.
Errors and technical changes reserved.
Manual_9621803_SpaceExplorer-NT-150-750-EQ_en_BRESSER_v022022a