

Digital Night Vision Device 3x Nightlux 200 Pro

Art. No. 1877492



About this instruction manual



Read the safety instructions and the instruction manual carefully before using this device.

Keep this instruction manual in a safe place for future reference. When the device is sold or given to someone else, the instruction manual must be provided to the new owner/user of the product.

General warnings



DANGER!

Children must only use the device under adult supervision. Keep packaging materials (plastic bags, rubber bands, etc.) away from children! There is a **DANGER OF CHOKING!**

Do not expose the device to high temperatures. Use only the recommended batteries. Do not short-circuit the device or batteries or throw them into a fire. Excessive heat and improper handling can cause short circuits, fires and even explosions!



FIRE HAZARD!

Do not expose this device - especially the lenses - to direct sunlight! The concentration of light rays could cause a fire.



DANGER OF AN ELECTRIC SHOCK!

This device contains electronic parts that are powered by a power source (batteries). Never leave children unattended when handling the device! Only use the device as described in the manual. Otherwise, you run the **DANGER** of an **ELECTRIC SHOCK**.



DANGER OF BURNS!

Leaking battery acid can lead to chemical burns. Avoid contact of battery acid with skin, eyes and mucous membranes. In the event of contact with acid, rinse the affected areas immediately with plenty of clean water and seek medical attention.



NOTE!

Do not disassemble the device! In the event of a defect, please contact your dealer. They will contact the Service

Centre and can arrange the return of this device for repair if necessary.

Use only the recommended batteries. Always replace weak or empty batteries with a new, complete set of batteries at full capacity. Do not use batteries from different brands or types or with different capacities. Remove batteries from the device if it is not in use for a long time!



Privacy PROTECTION!

The binoculars are intended only for private use. Respect the privacy of your fellow human beings - do not look into flats with this device, for example!

Scope of delivery

- › night vision device
- › shoulder strap
- › transport bag
- › instruction manual

8×AA/LR 6 batteries required (not included).

Device overview

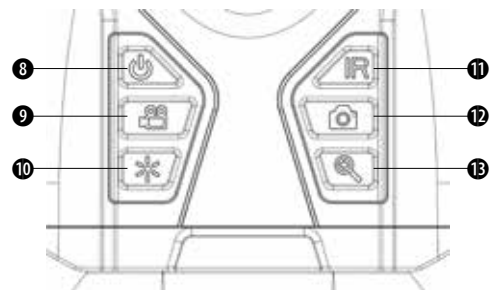
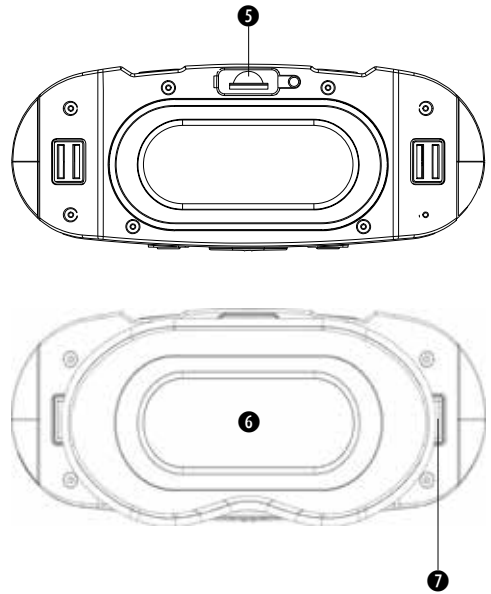
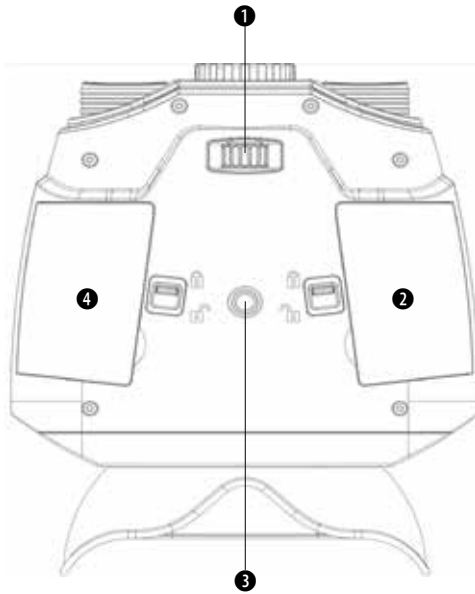

- ❶ Focus wheel - focus objective lens
- ❷ + ❹ Battery compartment (4 × AA batteries required)
- ❸ Tripod connection
- ❺ Micro SD card slot
- ❻ Viewing area
- ❼ Shoulder strap hook

- ❽ Power button (on/off)
- ❾ Video record button - Press to record a video.
- ❿ Screen Brightness - Press to adjust screen brightness.
- ⓫ IR button - Press for 7 brightness levels while using the night vision device at night.
- ⓬ Photo button - Press to take a photo.
- ⓭ Zoom button - Press to gradually zoom. The maximum zoom is 2 ×. When you have reached 2x, press the button again to return to 1x.

Inserting the batteries

Open the battery compartments (2 + 4) and insert 4 x AA batteries in each compartment. Pay attention to the polarity markings in the battery compartment.

Close the battery compartment cover.

Inserting/Removing the micro SD Card

Insert the micro SD card into the micro SD card slot 5 and press until it clicks into place.

To remove the installed micro SD card, please push the micro SD card inward to release it. When the card is partially ejected, pull it out.

Storage Capacity: 4 GB or more is recommended.

Note: The device will display "Please insert SD card" if the micro SD card is not installed.

Operating instructions

Turning the device on: Press and hold the power button 8 to turn the device on. Once the device is turned on, look at the LCD screen inside for a preview. Adjust the focus by turning the focus wheel 1 at the bottom of the front side. For night mode, turn on the infrared by pressing the IR button 11. Increase the brightness by pressing the button 10 repeatedly. There are 7 levels of brightness.

Adjusting screen brightness: Press the Screen Brightness button 10 for an adjustment in several steps up to 9. When you have reached 9, press again to go back to 0.

Using digital zoom: Press the zoom button 13 to zoom in up to 2x in multiple steps. When you have reached 2x, press again to return to 1x.

Taking a photo: Turn the device on by pressing the power button 8. Adjust the focus by turning the focus wheel 1. When taking pictures at night, adjust the brightness by pressing the IR button 11. Press the photo button 12 to take a picture.

Recording a video: Turn the device on by pressing the power button 8. Adjust the focus by turning the focus wheel 1. When recording at night, adjust the brightness by pressing the IR button 11. Press this record button 9 to start recording a video and press it again to stop recording.

LCD display information

Photo Mode

Press the photo button 12 to take pictures.

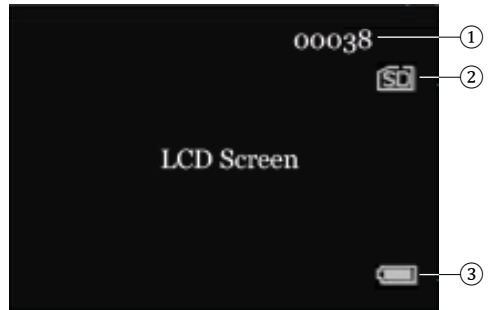

- ① Number of recorded files (including photos and videos).
- ② SD card installed and ready to save photos. When  is displayed, turn the device off and then insert the SD card.
- ③ Battery status indicator

Video Mode

Press the video record button 9 to start recording a video.



- ① Display video mode
- ② Minutes of recorded videos
- ③ SD card installed and ready to save videos. If  is displayed, turn the device off and then insert the SD card.
- ④ Battery status indicator
- ⑤ Indicator of screen brightness (0-9)

Troubleshooting

Turned off device:

- If the device does not turn on, check whether the batteries are defective, missing or not inserted correctly. Replace the batteries or insert them correctly. Be sure to use only alkaline batteries.

Poor image quality:

- If you wear glasses, please leave them on while using the device.
- When using the device during the day, please make sure the infrared is turned off. At night, make sure that the infrared function is turned on.
- Adjust the focus by slowly turning the focus wheel at the bottom of the binoculars' front side. Make sure it's focused.

Why does the message "No SD Card" appear on the screen while the micro SD card is inserted?

- Please turn the device off, insert the card, and check the screen again.
- If the problem persists, please check the micro SD card. In some cases, micro SD cards cannot be read due to compatibility issues. Try inserting a different micro SD card.

INSTRUCTIONS for cleaning

Before cleaning, disconnect the device from the power supply (remove batteries)! Only use a dry cloth to clean the exterior of the device. To avoid damaging the electronics, do not use any cleaning fluid. Clean the eyepieces and/or lenses only with a soft, lint-free cloth (such as a microfiber cloth). To avoid scratching the lenses, apply only gentle pressure with the cleaning cloth. Protect the device from dust and moisture. Keep it in the supplied bag or transport packaging. Remove the batteries from the device if it is not in use for a long time.

Specifications

Viewfinder	EVF mode
Aspect ratio	4:3
Aperture	F1.4 with adjustable aperture day and night dual mode
Operating mode	Preview
Visual distance	200 m at night, 500 m during the day
Objective lens focus	Manually adjustable
Visual angle	6.8° degrees
Brightness	IR LED
External memory	4GB to 32GB micro SD card
Power supply	8 × alkaline AA battery
Working time	Up to 10 hours in daytime mode, 6 hours in nighttime mode
Video recordings	Yes
Weight	450 g
Dimensions (height×width×depth)	159 mm × 149 mm × 68 mm

EC DECLARATION OF CONFORMITY

 A "Declaration of conformity" in accordance with the applicable directives and corresponding standards has been prepared by Bresser GmbH. This can be viewed at: www.bresser.de/download/1877492/CE/1877492.pdf

UKCA DECLARATION OF CONFORMITY

 Bresser GmbH has issued a „Declaration of Conformity“ in accordance with applicable guidelines and corresponding standards. The full text of the declaration of conformity is available at the following internet address: [www.bresser.de/download/1877492_UKCA.pdf](http://www.bresser.de/download/1877492/UKCA/1877492_UKCA.pdf)

Bresser UK Ltd. • Suite 3G, Eden House, Enterprise Way, Edenbridge, Kent TN8 6HF, Great Britain

DISPOSAL

 Dispose of the packaging materials properly, according to their type, such as paper or cardboard. Contact your local waste-disposal service or environmental authority for information about the proper disposal.

 Do not dispose of electronic devices in the household garbage!

According to the European Directive 2012/19/EU on Waste Electrical and Electronic Equipment and its transposition into national law, used electrical equipment must be collected separately and recycled in an environmentally sound manner.

Batteries and rechargeable batteries must not be disposed of with household waste. You are legally obliged to return used batteries and accumulators and can return the batteries after use either at our sales outlet or in the immediate vicinity (e.g. in the trade or in municipal collection points) free of charge. Batteries and accumulators are marked with a crossed-out dustbin and the chemical symbol of the pollutant, "Cd" stands for cadmium, "Hg" stands for mercury and "Pb" stands for lead.

WARRANTY & SERVICE

The regular guarantee period is 5 years and begins on the day of purchase.

You can consult the full guarantee terms as well as

information on extending the guarantee period and details of our services at www.bresser.de/warranty_terms.

Would you like detailed instructions for this product in a particular language? Then visit our website via the link below (QR code) for available versions.

Alternatively you can also send an email to manuals@bresser.de or leave a message on +49 (0) 28 72 – 80 74-220*. Please always state your name, precise address, a valid phone number and email address, as well as the article number and product name.

*Number charged at local rates in Germany (the amount you will be charged per phone call will depend on the tariff of your phone provider); calls from abroad will involve higher costs.

Errors and technical changes excepted.

DOWNLOAD INSTRUCTION MANUAL



<http://www.bresser.de/1877492>

SERVICE AND WARRANTY



www.bresser.de/warranty_terms

Please be prepared for service requests:

Art. No.: 1877492

Product name:
BRESSER Digital Night Vision Device
3x Nightlux 200 Pro

Instruction manual:

[Manual_1877492_Digital-Nightvision-3x-Nightlux-200-Pro_de_BRESSER_v042021a.pdf](#)

SERVICE

DE AT CH BE

Bei Fragen zum Produkt und eventuellen Reklamationen nehmen Sie bitte zunächst mit dem Service-Center Kontakt auf, vorzugsweise per E-Mail.

E-Mail: service@bresser.de
Phone*: +49 28 72 80 74 210

BRESSER GmbH
Kundenservice
Gutenbergstr. 2
46414 Rhede
Deutschland

*Lokale Rufnummer in Deutschland (Die Höhe der Gebühren je Telefonat ist abhängig vom Tarif Ihres Telefonanbieters); Anrufe aus dem Ausland sind mit höheren Kosten verbunden.

GB IE

Please contact the service centre first for any questions regarding the product or claims, preferably by e-mail.

E-Mail: service@bresseruk.com
Telephone*: +44 1342 837 098

Bresser UK Ltd.
Suite 3G, Eden House
Enterprise Way
Edenbridge, Kent TN8 6HF
United Kingdom

*Number charged at local rates in the UK (the amount you will be charged per phone call will depend on the tariff of your phone provider); calls from abroad will involve higher costs.

FR BE

Si vous avez des questions concernant ce produit ou en cas de réclamations, veuillez prendre contact avec notre centre de services (de préférence via e-mail).

E-Mail: sav@bresser.fr
Téléphone*: 00 800 6343 7000

BRESSER France SARL
Pôle d'Activités de Nicopolis
314 Avenue des Chênes Verts
83170 Brignoles
France

*Prix d'un appel local depuis la France ou Belgique

NL BE

Als u met betrekking tot het product vragen of eventuele klachten heeft kunt u contact opnemen met het service centrum (bij voorkeur per e-mail).

E-Mail: info@bresserbenelux.nl
Telefoon*: +31 528 23 24 76

BRESSER Benelux
Smirnofstraat 8
7903 AX Hoogeveen
The Netherlands

*Het telefoonnummer wordt in het Nederland tegen lokaal tarief in rekening gebracht. Het bedrag dat u per gesprek in rekening gebracht zal worden, is afhankelijk van het tarief van uw telefoon provider; gesprekken vanuit het buitenland zullen hogere kosten met zich meebrengen.

ES IT PT

Si desea formular alguna pregunta sobre el producto o alguna eventual reclamación, le rogamos que se ponga en contacto con el centro de servicio técnico (de preferencia por e-mail).

E-Mail: servicio.iberia@bresser-iberia.es
Teléfono*: +34 91 67972 69

BRESSER Iberia SLU
c/Valdemorillo, 1 Nave B
P.I. Ventorro del Cano
28925 Alcorcón Madrid
España

*Número local de España (el importe de cada llamada telefónica dependen de las tarifas de los distribuidores); Las llamadas des del extranjero están ligadas a costes suplementarios..

Bresser GmbH
Gutenbergstr. 2
46414 Rhede · Germany
www.bresser.de

    @BresserEurope

